

**TRANSMISSION THROTTLE VALVE
ACTUATOR PARTIAL ELECTRICAL SCHEMATIC**

ENGINE CONTROL MODULE
(located on the front drivers side of engine)

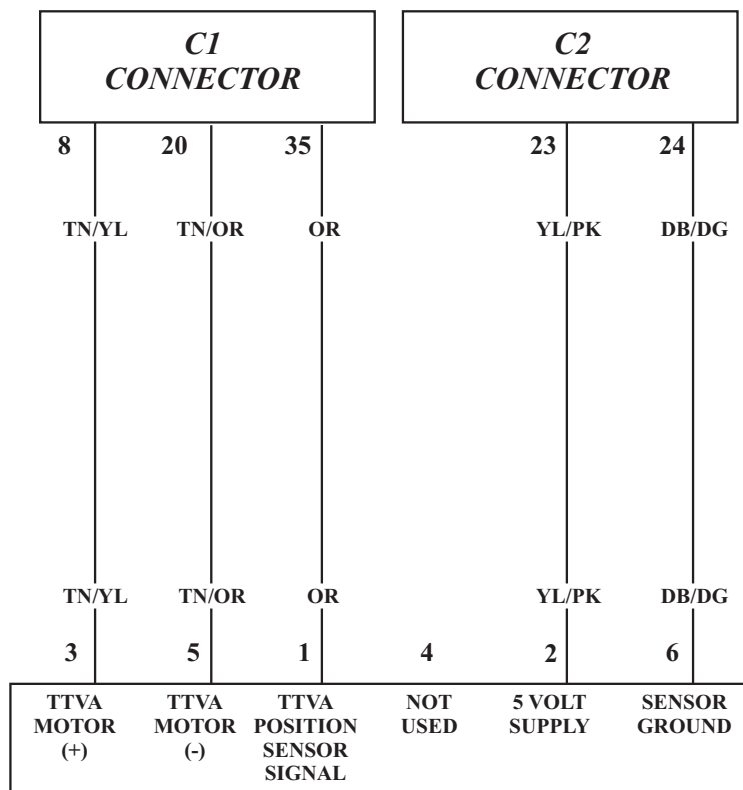

**TRANSMISSION THROTTLE VALVE
ACTUATOR CONNECTOR**

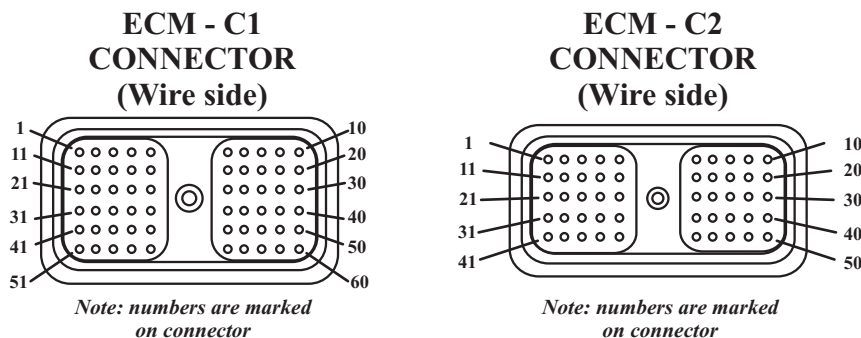

**TRANSMISSION THROTTLE VALVE
ACTUATOR CONNECTOR (Face view)**

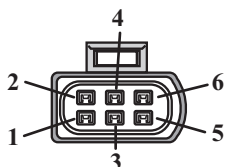

Figure 3